

SPA LIFT ELITE (68)



Item# F-006SLE

The Spa Lift Elite is a fully powered ADA compliant lift designed especially to provide access to elevated pools and spas. Pair it up with a swim spa and enjoy the benefits of aquatic exercise, improved health, and increased independence. The Elite offers easy push button controls and 360 degrees of rotation.

The Spa Lift Elite is constructed of quality stainless steel and coated with a durable powder coat finish. Whether relaxation, rehabilitation, or socialization is your goal, the Spa Lift Elite is the solution to stress-free access to your personal backyard or commercial spa.



*New footrest not shown



FEATURES:

- UL Certified
- 300 lb (136 kg) weight capacity
- Clearances vary by wall height & width
- Wall height range 21" - 68" (54 - 172 cm)
- 360 degree powered rotation in either direction
- Adjustable pull-out leg rest
- Flip-up armrests
- Five year structural warranty
- Five year pro-rated electronics warranty

ACCENT COLORS

Available in a variety of accent and powder coat colors



*Blue seat standard (not a powder coat option)

OPTIONS/ACCESSORIES:

F-SPAAK8	Anchor, standard tri-point anchor system
F-107UEWDA	Anchor, wood deck applications
F-450SLECS	Cover, standard lockable, blue
F-450SLECS-T	Cover, standard lockable, tan
F-450SLECS-G	Cover, standard lockable, gray
F-422PLH-2	Headrest
F-042SCH	Solar charging station

PROUDLY SOLD BY:

strack Liftsysteme

Strack AG
Ebnetstrasse 125
8200 Schaffhausen

Tel. 0800 600 500
Fax 0800 600 900

www.strack.ch
info@strack.ch

ZSR-Nr. K 7514.14
NIF-Nr. 366 824
MWST-Nr. 567 970

THE SPA LIFT ELITE

PRODUCT SPECIFICATIONS

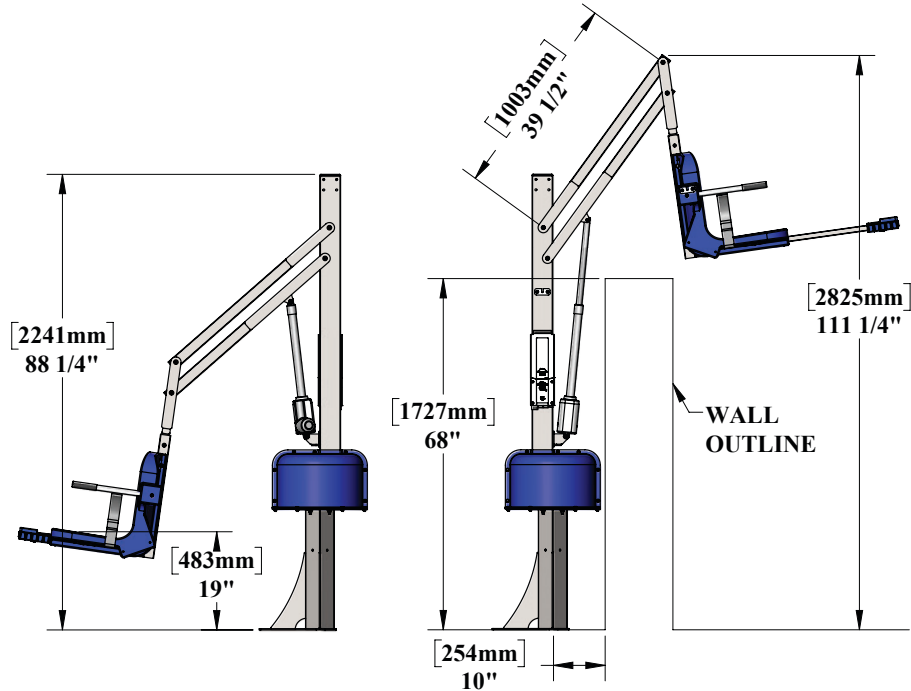

APPLICABLE POOL PROFILES

RAISED POOL / SPA

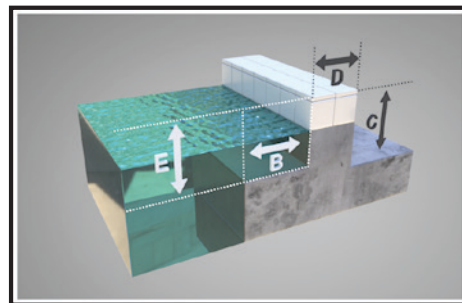

To confirm specific application go to www.aquacreek.com for our Pool Lift Selector
Become a member of our new Dealer and Architect page. Access to CAD blocks,
CSI specs and sales materials.